

Zilla® Electrical Flashing Installation

Use the following instructions to install the Zilla® Electrical Flashing (patent pending) on asphalt shingled roofs and vertical walls.

Parts included in the assembly:

- Zilla® Electrical Base Plate
- Zilla® Electrical Flashing
- Zilla® LB Flashing Adapter with 2 O-rings
- 6 - #10 x 1.5" Spax, wood to wood, zinc plated screws

Parts & Tools needed (in addition to the assembly):

- 1.75" diameter hole saw
- Phillips screwdriver or drill driver with #2 bit

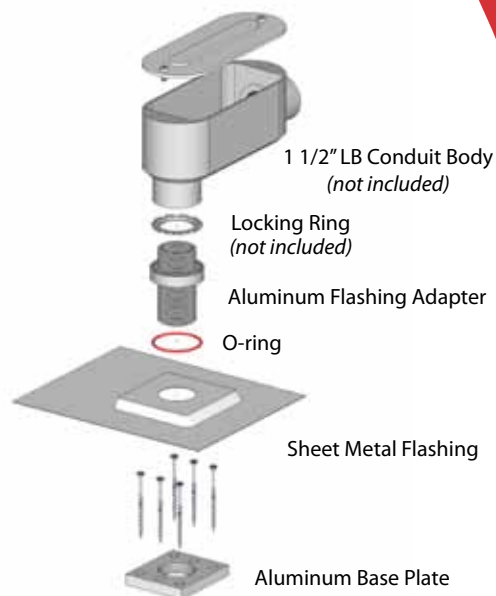

Installation Steps

Step 1 - Create an access hole



- 1: The Electrical Flashing is designed to slide beneath the shingles above the point of roof penetration. Choose the general area on the roof where you wish to create a hole. Make sure there are no joists or bracing directly beneath where you plan to create your hole.
- 2: Measure 2.5" - 2 5/8" down from the edge of the upper shingle where you wish to drill and create a center mark for your hole.

Step 2 - Mount the Electrical Base Plate



- 3: Place the plate face down on the shingles with the counter sunk hole features facing up. Align the center hole over the hole through the roof. Rotate the Electrical Base Plate so it's square and level with the shingles.
- 4: Use a #2 Phillips head bit to drive the 6 Spax screws into the base plate to screw it into the roof sheathing.

Patent(s) Pending.

Step 3 - Attach the Electrical Flashing

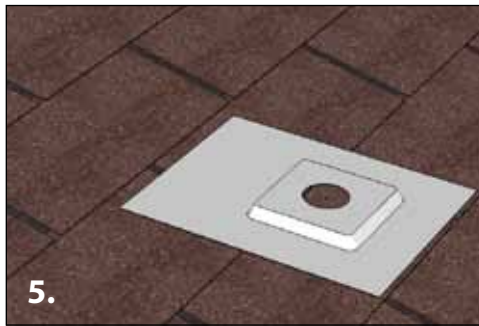

- 5: Slide the longest end of the Electrical Flashing beneath the shingles directly above the Base Plate.
6: Keep the angle of the flashing parallel with the roof so you don't disrupt the existing shingles or existing materials. Align the hole in the flashing with the hole in the base plate.

Step 4 - Mount the LB Flashing Adapter

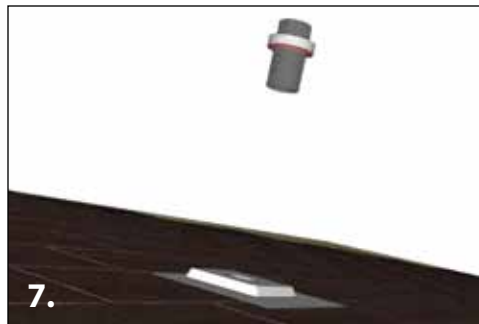

- 7: Ensure the silicone o-ring is inserted into the channels at the longer end of the adapter and apply a thin coating of silicone grease or vaseline on the exposed surfaces of the silicone o-ring. Attach a conduit at the end of the longer threaded portion of the LB Flashing Adapter if desired.
8: Thread the longer end of the adapter through the flashing and into the base plate. Thread until the silicone rubber o-ring is fully seated against the flashing.



- 9: Cut hole in junction box and slip over shaft and lock w/ nut.
10: Thread locking nut on shaft, then thread body on shaft and tighten with locking nut.

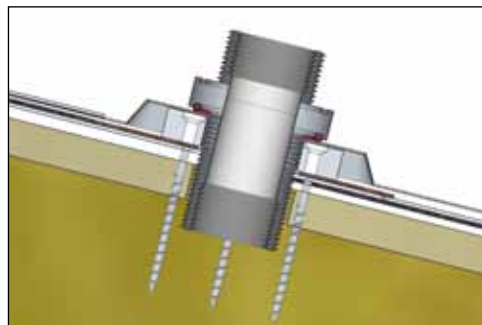

855.670.1212 | zillarac.com

Patent(s) Pending.

Disclaimer: The installer is fully responsible for getting the system verified and approved for all local and state building codes and all Authorities Having Jurisdiction AHJ. Zilla Corporation assumes no liability whether assumed or implied.
Copyright © 2011 Zilla Corporation. All rights reserved. Made in the U.S.A. Patented and patents pending.